

# Clarke®

## STRONG-ARM



### BOTTLE JACK

MODEL NO: CBJ32

PART NO: 7620052

## OPERATION AND MAINTENANCE INSTRUCTIONS

UK  
CA | CE

ORIGINAL INSTRUCTIONS

DL0122 - Rev 1

---

## INTRODUCTION

---

Thank you for purchasing this CLARKE Bottle Jack.

Before attempting to use this product, please read this manual thoroughly and follow the instructions carefully. In doing so you will ensure the safety of yourself and that of others around you and you can look forward to your purchase giving you long and satisfactory service.

Keep these instructions for future reference.

---

## GUARANTEE

---

This product is guaranteed against faulty manufacture for a period of 12 months from the date of purchase. Please keep your receipt which will be required as proof of purchase.

This guarantee is invalid if the product is found to have been abused or tampered with in any way, or not used for the purpose for which it was intended.

Faulty goods should be returned to their place of purchase, no product can be returned to us without prior permission.

This guarantee does not effect your statutory rights.

---

## SPECIFICATIONS

---

Rated Load	32 tonne
Min Height of saddle	230 mm
Max Height of saddle	360 mm
Number of pump actions from rest to max height	146
Oil type	ISO13 Hydraulic jack oil
Pump oil capacity	0.52 L
Dimensions (L x W x H) mm	170 x 130 x 230
Weight	15.9 kg
Length of Operating Handle	660 mm

---

## **SAFETY PRECAUTIONS**

---

1. DO NOT exceed the rated capacity of the jack.
2. DO NOT let anyone operate the jack unless they have read these safety precautions.
3. DO NOT operate the jack if damaged in any way.
4. Use the jack in a well lit work area.
5. Keep the work area clean and tidy and free from unrelated items.
6. Only use the jack on level and solid ground, preferably concrete. Never use it on soft/unmade ground as the jack may sink in.
7. Make sure that non-essential persons keep a safe distance whilst the jack is in use.
8. Make sure there are no people or obstructions under the vehicle before lowering.
9. DO NOT work below the vehicle until it is fully supported by axle stands.
10. Keep your hands clear of the vehicle until lifting is complete.
11. Make sure that you can see the saddle and jacking point throughout the jacking operation in case there is any relative movement.
12. ALWAYS make sure that the jack saddle is centred and stable on the lifting point before lifting and position the jack to avoid operating it from under the vehicle.
13. Check the vehicle weight and location of the lifting points by referring to the vehicle owners manual.
14. DO NOT tamper with the jack or modify it in any way, as this could prove to be dangerous and will invalidate the guarantee.
15. Only use the jack for the purpose for which it is intended.
16. Use applicable safety equipment, such as protective footwear, when you use this jack.
17. Make sure that the jack is correctly maintained and lubricated at all times, and that no corrosion is allowed to weaken any part of it.
18. If the jack has been subjected to an abnormal load or shock, it should be removed from service immediately and fully inspected by qualified personnel, and passed as serviceable, before being used again.
19. When not in use, store the jack, fully lowered, in a safe, dry, childproof area.

20. ALWAYS examine the jack before use. Make sure that all parts are in good condition and operating smoothly, and that no cracks or distortion is apparent. If in doubt do not use.
21. DO NOT push a vehicle off the jack or start the engine while supported only by the jack.
22. DO NOT use if an oil leak is apparent. Consult the Clarke Service Department.
23. If more than one jack is used in unison, they must all be of the same rating and be raised at the same speed to reduce the possibility of the load slipping.

## **LIFTING OPERATIONS AND LIFTING EQUIPMENT REGULATIONS 1998**

This jack, depending on use, may fall within the scope of LOLER. It is the owner's responsibility to determine whether or not it does and, if so, to comply with any applicable requirements in LOLER, for having the jack thoroughly examined.

## **ENVIRONMENTAL PROTECTION**

1. ALWAYS take care to ensure that if hydraulic oil is spilt that it is cleaned away using sand or treated with absorbent granules designed for the purpose.
2. ALWAYS make every effort to contain any spillage and prevent ingress into the local water course.
3. DO NOT allow any spilt oil to penetrate the ground or soil.
4. ALWAYS dispose of any old oil at a local recycling centre.

# OVERVIEW

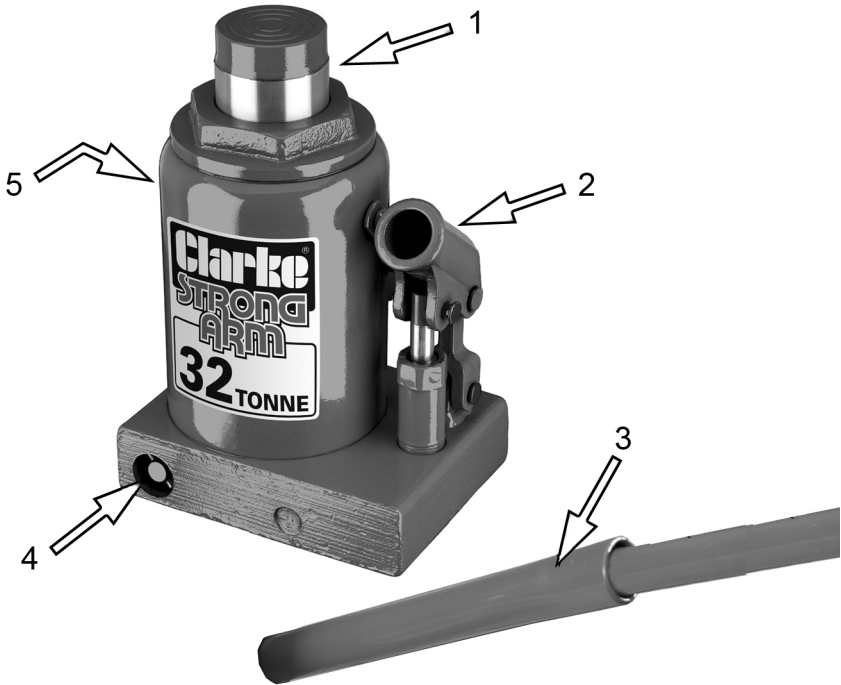

1	Ram
2	Actuating Lever
3	3 x Handle Tubes
4	Release Valve
5	Oil Filler Plug (behind unit)

## UNPACKING

During transit or storage, it is possible that an air pocket may have developed within the hydraulic ram, and the ram action may therefore appear to be 'spongy'. In this case the jack may require purging as described on page 8.

If the jack does not reach its full height, the oil level may require topping up as described in the Maintenance section on page 7.

---

# OPERATION

---



**WARNING: MAKE SURE THAT THE SAFETY PRECAUTIONS ARE STRICTLY FOLLOWED. NO RESPONSIBILITY CAN BE ACCEPTED FOR INCORRECT USE OF THE JACK**

---

## RAISING A VEHICLE

1. Make sure that the vehicle is stable and is on firm level ground with the wheels chocked before positioning the jack directly below the lifting point. DO NOT rely upon the vehicle handbrake alone to prevent vehicle movement.
2. Make sure that the jack is on solid ground. If not, place a piece of solid wood of sufficient size to provide sufficient support below the jack.
3. Consult the vehicle owners manual to ascertain the location of the lifting points and position the jack below the designated lifting point.
4. Locate the slotted end of the jack handle on to the release valve and turn fully clockwise to close the valve.
5. Pump the handle and raise the ram so that the jack and lifting point are in full contact. Before proceeding further, make one last check to make sure that:
  - the jack is vertical and stable.
  - there are no obstructions to the lift and that the handle can move freely up and down.
  - all personnel are in a safe position.
6. When satisfied, continue to pump the handle and lift the load to the height required.
7. Do not let anyone reach or work below the vehicle until it is firmly supported on suitable axle stands.

## LOWERING THE VEHICLE



**WARNING: ALWAYS LOWER IN A SLOW AND CONTROLLED MANNER, AND CHECK THAT THERE ARE NO OBSTACLES IN THE PATH OF THE LOAD'S DESCENT. BE VERY CAREFUL WHEN LOWERING HEAVY LOADS.**

---

1. The lowering speed is controlled by the amount you turn the release valve. With the axle stands removed, check to make sure that there are no

personnel in the immediate vicinity before removing the handle from its housing, and engaging it with the release valve.

2. Very slowly turn the handle counterclockwise to open the release valve, and let the jack lower the load, under complete control. Do not open the valve suddenly.

---

## MAINTENANCE

---

***IMPORTANT: Only fully qualified personnel should attempt to repair the jack.***

### INSPECTION

1. Always examine the jack before use, to ensure that all parts are correctly located and secure. Check for hydraulic leaks, signs of damage or worn parts. **Do not use the jack unless it is perfectly serviceable.**
  - A slight dampness on the ram is normal, but where leakage is found, the ram seals must be renewed by your CLARKE Spares Department.
2. The jack must be fully inspected annually:
  - Check for cracks and deformation of components.
  - Check operation and top up the oil level. (see below).
  - Remove rust or corrosion and repaint to prevent corrosion.
3. After use, store the jack with the ram in its lowest position. This not only releases the pressure in the hydraulic ram, but also prevents any possibility of corrosion to the ram.
4. Do not leave the jack in the open, exposed to the weather. Keep under cover. If stored for long periods, examine before use, clean, and re-oil. For servicing, speak to your CLARKE dealer or CLARKE Service department.

### TOPPING UP THE OIL

It can be necessary from time to time to top up the hydraulic oil level as follows.

1. Turn the release valve counterclockwise and let the ram retract to its lowest position.
  - It can be necessary to apply force to the saddle for lowering without any weight on the jack.
2. With the jack in the level position, remove the filler plug and stand upright.
  - The oil should be level with the bottom of the oil filler hole.
3. If below this, top up.

4. Do not overfill. Only use the correct type of oil such as CLARKE hydraulic oil, part number 3050830 (1 litre).
5. Replace the filler plug.
6. Check the jack for correct operation and purge any air from the system as described below.

## **PURGING AIR FROM THE JACK**

1. Turn the release valve counterclockwise one full turn to open.
2. Pump the handle eight full strokes.
3. Turn the release valve clockwise to close the valve.
4. Pump the handle until the ram reaches maximum height and continue to pump several times to remove trapped air.
5. Turn the release valve counterclockwise one full turn and lower the ram to its lowest position. Apply pressure if necessary.
6. Turn the release valve clockwise to the closed position and check for correct operation. It may be necessary to perform the procedure more than once to evacuate all the air.

## **TROUBLESHOOTING**

<b>Problem</b>	<b>Reason</b>	<b>Solution</b>
Jack will not lift to full height	Low oil level	Check oil level & top up as necessary.
Jack will not hold load	Release valve not closing Hydraulic oil contaminated Pump valves not sealing Cylinder ram binding	Speak to the CLARKE Service Department
Jack piston will not lower	Cylinder ram binding Internal parts worn Internal damage	Speak to the CLARKE Service Department
Jack feels spongy when lifting	Air trapped in the hydraulic system	See air purging procedure above



# PARTS DIAGRAM

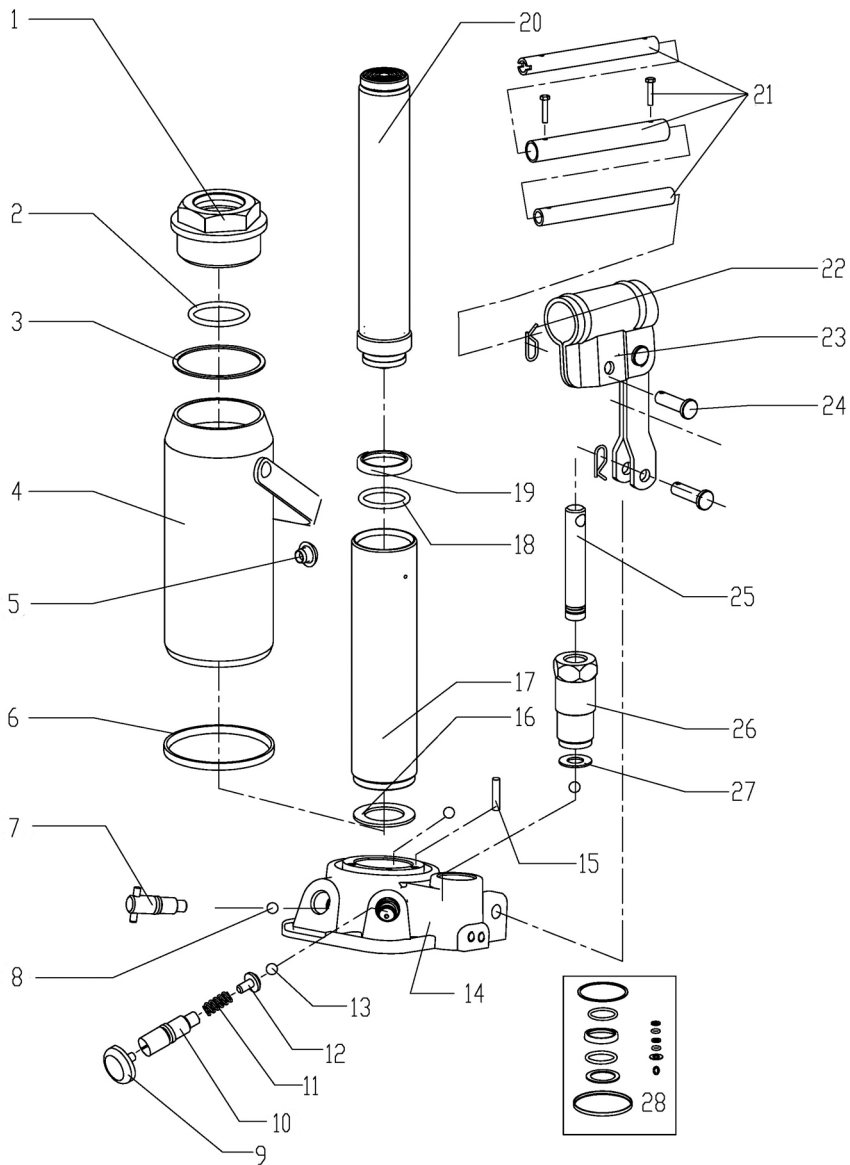

## PARTS LIST

No	DESCRIPTION
1	Top cup
2	O-ring
3	Rectangular ring
4	Reservoir
5	Oil plug
6	T-ring
7	Release valve assembly
8	Ball 6mm
9	Plastic plug
10	Adjusting screw assembly
11	Spring
12	Spring holder
13	Steel ball 3mm
14	Base parts
15	Oil filter pipe
16	Cylinder ring
17	Cylinder
18	O-Ring
19	Bowl washer
20	Piston rod assembly
21	Handle assembly and Hexagon bolts
22	Cutter pin
23	Handle socket assembly
24	Pin
25	Pump plunger assembly
26	Pump
27	Washer
28	Seal kit

# DECLARATION OF CONFORMITY



Fitzwilliam Hall, Fitzwilliam Place, Dublin 2

## DECLARATION OF CONFORMITY

This is an important document and should be retained.

We hereby declare that this product(s) complies with the following directive(s):  
2006/42/EC Machinery Directive.

The following standards have been applied to the product(s):  
EN 1494:2000+A1:2006, EN ISO 12100:2010.

The technical documentation required to demonstrate that the product(s) meet(s) the requirement(s) of the aforementioned directive(s) has been compiled and is available for inspection by the relevant enforcement authorities.

The CE mark was first applied in: 2020

Product Description: 32 Tonne Hydraulic Bottle Jack  
Model number(s): CBJ32  
Serial / batch Number: N/A  
Date of issue: 11/01/2022

Signed:

J.A. Clarke  
Director

CBJ32 CE Clarke DOC 011122

Page 1 of 1



Hemmel Street, Epping, Essex CM10 4LG

## DECLARATION OF CONFORMITY

This is an important document and should be retained.

We hereby declare that this product(s) complies with the following statutory requirement(s):  
Supply of Machinery (Safety) Regulations 2008

The following standards have been applied to the product(s):  
EN 1494:2000+A1:2006, EN ISO 12100:2010.

The technical documentation required to demonstrate that the product(s) meet(s) the requirement(s) of the aforementioned legislation has been compiled and is available for inspection by the relevant enforcement authorities.

The UKCA mark was first applied in: 2021

Product Description: 32 Tonne Hydraulic Bottle Jack  
Model number(s): CBJ32  
Serial / batch Number: N/A  
Date of issue: 11/01/2022

Signed:

J.A. Clarke  
Director

CBJ32 UKCA Clarke DOC 011122

Page 1 of 1

# A SELECTION FROM THE VAST RANGE OF

# Clarke®

## QUALITY PRODUCTS



### AIR COMPRESSORS

From DIY to industrial, Plus air tools, spray guns and accessories.

### GENERATORS

Prime duty or emergency standby for business, home and leisure.

### POWER WASHERS

Hot and cold, electric and engine driven - we have what you need

### WELDERS

Mig, Arc, Tig and Spot. From DIY to auto/industrial.

### METALWORKING

Drills, grinders and saws for DIY and professional use.

### WOODWORKING

Saws, sanders, lathes, mortisers and dust extraction.

### HYDRAULICS

Cranes, body repair kits, transmission jacks for all types of workshop use.

### WATER PUMPS

Submersible, electric and engine driven for DIY, agriculture and industry.

### POWER TOOLS

Angle grinders, cordless drill sets, saws and sanders.

### STARTERS/CHARGERS

All sizes for car and commercial use.

## PARTS & SERVICE:

## 0208 988 7400

### Parts Enquiries

[Parts@clarkeinternational.com](mailto:Parts@clarkeinternational.com)

### Servicing & Technical Enquiries

[Service@clarkeinternational.com](mailto:Service@clarkeinternational.com)

SALES: UK 01992 565333 or Export 00 44 (0)1992 565335

**Clarke** INTERNATIONAL Hemnall Street, Epping, Essex CM16 4LG  
[www.clarkeinternational.com](http://www.clarkeinternational.com)